

Economic Climate Model of the Oil Palm Production in Malaysia

Ali Chizari, Zainalabidin Mohamed, Mad Nasir Shamsudin, Kelly Wong Kai Seng

Department of Agribusiness and Bioresource Economics, Faculty of Agriculture, UPM

Abstract— Climate change is arguably one of the most important factors influencing agricultural production in developing countries such as Malaysia. Therefore, it becomes important to explore the impacts of climate change on agricultural yield and production. Cocoa was brought to Malaysia for commercial planting in the 1950s. The palm oil industry grew to become the first major commodity crop in Malaysia. This study applied the autoregressive distributed lag (ARDL) co-integration approach over the periods (1980 – 2014). There are two main methods including the Regional Climate Model (RCM) which can reasonably produce appropriate projections that can be used for climate scenario generation in a country-scale. Based on this information, this study considered three scenarios: 1) First Scenario, Rainfall changes 2) Second Scenario, Temperature changes 3) Third Scenario, Scenario 1 and 2 simultaneously. Preliminary results from the Autoregressive Distributed Lag (ARDL) model applied indicated that despite the projected changes in the climate variables (temperature and rainfall), in scenario 1 (the projected changes (5% increase) in rainfall). The result showed that climate variables (rainfall and temperature) have negative impacts on palm oil yield. The production trend is expected to be positive while changes in rainfall (5% increase), changes in temperature (2% increase) and simultaneous changes in rainfall (+5%) and temperature (+2%) will cause the yield to decline by 0.24%, 0.58%, and 0.82% respectively.

Keywords— Climate Model, Oil Palm, Malaysia, ARDL.

I. INTRODUCTION

The Malaysian palm oil industry has now prevailed as one of the most prominent in the worldwide oils and fats market. Interests in oil palm planting continue to increase due to its monetary advantage and motivating improvement in yield that outperformed the average worldwide oils and fats development. The worldwide production of palm oil has multiplied in the last decade due to the rising overall interest in palm oil and palm oil products. With about 61.1 million tonnes produced in 2015, it represents the most widely consumed vegetable oil around the world. It has the highest yield compared to other sources of oil and is the least expensive vegetable

oil to produce and refine (Arbeitsgemeinschaft Energiebilanz (AGEB), 2015). Palm oil production is expected to reach 240 million tonnes by 2050. New estates are being developed and existing ones are being expanded in Malaysia and especially in Indonesia, also in Africa and Latin America (WWF, 2016).

In 2012, the Malaysian government approved an investment of RM548.7 million for the plantation and commodities sub-sector, all of which were domestic investments (MPOB, 2015). A total of RM362.8 million or 66.1% of the investment was for the production of palm oil, while RM185.9 million (33.9%) was for the production of rubber. Malaysia's palm oil industry remains one of the country's most important industries. Overall, the Malaysian state's palm oil sector is expected to generate RM22.4 billion in investments by the year 2020. Under the National Key Economic Areas (NKEA), investment in palm oil is targeted to reach RM178 billion by 2020 (Malaysian Investment Development Authority (MIDA), 2012). The industry also plays a significant role in the Malaysian economy as palm oil represents the fourth largest contributor to the GNI (Gross National Income), contributing RM63 billions of GNI in 2015 which was below the targeted amount of RM69.3 billion, a short of RM6.3 billion (Bank Negara Malaysia, 2016). Nevertheless palm oil industry is still a major contributor to the country's GDP (Gross Domestic Product). The palm oil industry accounts for 5-6% of Malaysia's GDP, and the importance of the industry to the country's export earnings is also very significant (MPOB, 2015). To bolster waste-to-riches activities, the National Biomass Strategy 2020 was propelled in 2013 to survey how Malaysia can develop new businesses through the efficient utilisation of farm biomass wastes. The palm oil biomass pellets can be used for power generation and other purposes such as the production of fiberboards with medium-thickness (11th Malaysia Plan, 2016-2020). In 2015 the planted areas of oil palm in Malaysia were distributed between Peninsular Malaysia, Sarawak and Sabah. About 42% of the planted areas are in Peninsular Malaysia, 24% in Sabah and 20% in Sarawak. In recent years, most of the expansion took place in the East Malaysian states of Sarawak and Sabah due to the declining availability of land in Peninsular Malaysia

(from 52% to 42% of total palm plantation (MPOB, 2015).

According to historical data, the Fresh Fruit Bunch yield witnessed an average growth of 9.4% from 2010-2014. However, the yields also fluctuated between these periods and average annually (from 16.38 t/ha to 17.92 t/ha), then (16.37 t/ha to 17.92 t/ha). With an equal growth rate achieved in Peninsular Malaysia, a lower rate of 1.8% (from 17.91 t/ha reached to 18.23 t/ha) was recorded compared to 5.9% (from 20.16 t/ha reached to 21.34 t/ha) and 8.3% (from 14.89 t/ha reached to 16.13 t/ha) recorded in Sabah and Sarawak respectively. Currently, the largest palm oil producing states in Malaysia are the peninsular states and accounting for 52% of the average total production in 2014 (18.23 t/ha FFB yield). Also, Sarawak with the lowest yield (an average of 16.11 t/ha in the last five years) has the highest yield growth (8.3% growth rate) (MPOB, 2015).

The factors affecting palm oil yield include the development of plantations in marginal areas with inappropriate soils, inadequate use of the agronomic inputs required for maintaining yields (especially during low palm oil prices), inadequate access to best practices and in recent years the impact of climate change on production and yield. Studies have also shown that oil palm cultivation increased as a result of aggregate decline in plantation areas available for rubber, cocoa, and coconut cultivation. This is particularly apparent in the period after the mid 2000's. The period prior to that demonstrated a marked upward trend for oil palm areas while the other crops remained relatively stable, suggesting that oil palm augmentation was largely attributed to deforestation (Jamal Othman, & Yaghoob Jafari, 2014).

Most of the Malaysian and Global studies demonstrate that changes in the climate is serious and there's a pressing need to figure out the effects and consequences. Paterson et al. (2015) have found that the ideal mean maximum temperature for palm oil is between 29 °C to 33 °C while the ideal mean minimum temperature is between 22 °C to 24 °C. Temperatures below 20 °C and above 36 °C are unsuitable for growth. Zahid Zainal et al. (2012) indicated that climate change has negative impact on net revenue. Vaghefi et al. (2011) reported that a 2°C increase in temperature diminishes Malaysian rice yield by 0.36 tonne for every section of land, which relates to a budgetary loss of roughly RM162.531 million every year

under such environmental situation. Any unfavourable atmosphere will certainly affect rural development (Murad et al., 2010). Based on this, climate change is a critical issue that needs to be taken into consideration to ensure optimum yields. Different measures of product development are available for adjusting to environmental change and minimizing its effect in cases of eccentric climate (Adger et al., 2007).

Finally, the impact on agriculture due to the threats and effects of climate change is therefore compelling and urgent. Not addressing the challenges and the urgency of collective actions is going to be catastrophic. The way forward requires increased understanding and awareness to cope with the interdependencies and interactions of natural resources and climate change, the vulnerabilities and interdisciplinary efforts.

The general objective of this study is to find impacts of climate change on production and yield.

The specific objectives are:

- 1) To develop oil palm market model
- 2) To investigate the relationship between climate change and oil palm yield
- 3) To estimate, forecast and simulate the level of production based on climate changes until 2020
- 4) To suggest policy alternative to mitigate impact of climate changes in sustaining oil palm production.

II. METHODOLOGY

Econometric Model is applied in this study simply because it has the competencies to set the climate change and economic variables as a climate-economic model (CEM) (Auffhammer et al., 2013; Pindyck, 2013; Nelson et al., 2014; Dell et al., 2014). The calculated F-statistics value is compared with two sets of critical values estimated by Pesaran et al. (2001). One set assumes that all variables are I(0) and other assumes they are I(1). If the calculated F-statistics exceeds the upper critical value, the null hypothesis of no co-integration is rejected irrespective of whether the variable are I(0) or I(1). If it is below the lower critical value, the null hypothesis of no co-integration cannot be rejected. If it falls inside the critical value bands, the test is inconclusive.

According to Labys (1973) and Shamsudin (2008) the conceptual framework of the oil palm and the details of structure are presented in Figure 1.

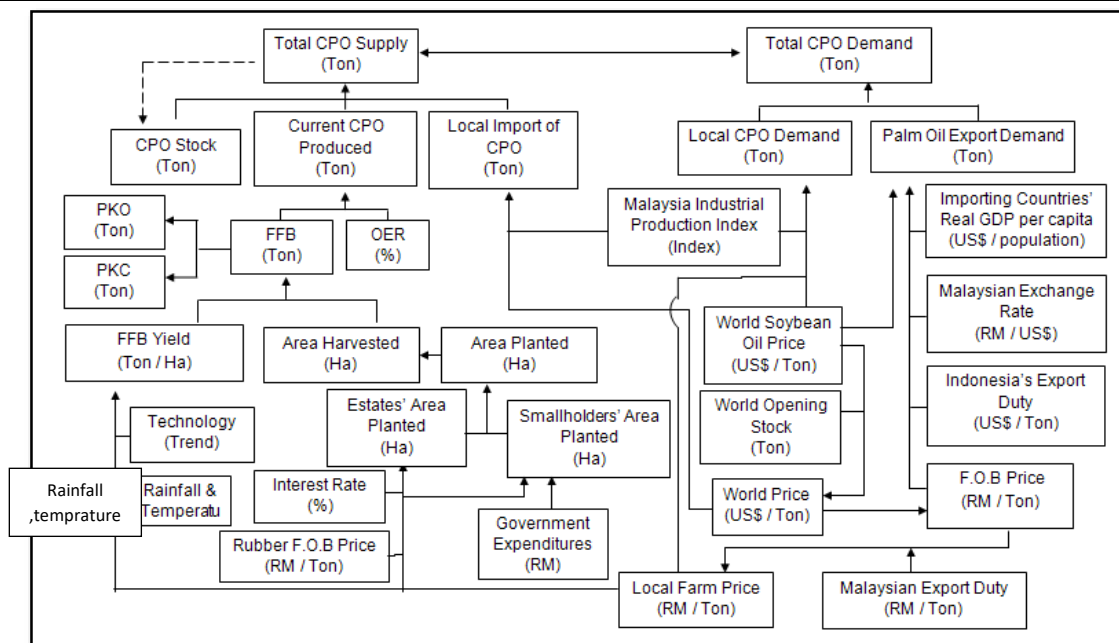

Fig.1: Conceptual Framework for Palm Oil Market Model

Based on the production function, the FFB production is determined by its inputs namely harvested area, farm price, and technology. Talib & Darawi (2002) and Asari, et al. (2011) demonstrate that the climate change alternatives should be considered as one of the important causes in determining the palm oil production.

Based on the production function, the FFB production is determined by its inputs namely harvested area, farm price, and technology. Talib & Darawi (2002) and Asari, et al. (2011) demonstrate that the climate change alternatives should be considered as one of the important causes in determining the palm oil production. Therefore, the rainfall and temperature are addition to the FFB yield function to find these influences as follows:

$$PCYD_{TO,t} = f(PCFP_t, FTP_t, RAIN_t, TEMP_t, trend)$$

where,

$$PCYD_{TO} = \text{Fresh Fruit Bunch}$$

(tonne/hectare/year)

$$PCFP = \text{Crude palm oil farm price}$$

(RM/tonne)

$$FTP = \text{Fertiliser price (RM/tonne)}$$

$$RAIN = \text{Average annual rainfall (mm)}$$

$$TEMP = \text{Average annual temperature}$$

(°C)

$$Trend = \text{Trend dummy proxy for}$$

technology

$$t = \text{Time period}$$

Diagnostic Tests

This study used the Auto Regressive Distribution Lag ARDL model and adopted the Unit test (Table 1), ARDL

bounds test (Table 2), and a series of diagnostic and stability tests. The model should be validated through historical simulation. The model is selected on the basis of the Schwartz-Bayesian Criteria (SBC) and Akaike's Information Criteria (AIC) (Table 3). All the simulation results will be compared and contrasted with the actual data gathered. The closeness and deviation of the estimation results and actual values are scaled by the Root Mean Square Error (RMSE), Root Mean Square Percentage Error (RMSPE), and U-Theil inequality coefficient (Table 4). The results indicate the absence of any instability of the coefficients because the plot of the CUSUM and CUSUMSQ statistic fall inside the critical bands of the 5% confidence interval of parameter stability (Figure 3, 4). For the out-of-sample validation purposes, the endogenous variables are projected based on the actual values of exogenous. The comparison results in out-of-sample are shown in Table 5.

Simulation Model

In order to forecast and simulate the commodity model, we have determined 2014 as the base year. According to Kwan Kok Foo (2010), there are two main methods and the one we used is the Regional Climate Model (RCM) which can produce reasonably appropriate projections to be used for climate-scenario generation in country-scale. Based on this information this study has considered three scenarios:

1. First Scenario -Rainfall changes: Based on rainfall changes in Malaysia in 2020 which will increase +6% more than normal trend
2. Second Scenario -Temperature changes: Based on temperature changes in Malaysia in 2020

which will increase +1.15°C more than normal trend

3. Third Scenario - Scenario 1 and 2 together

III. RESULTS

The Climate Palm Yield equation was determined by the technology trend (T), lagged one year annual yield adjusted (PCYD_{T0,t-1}), and palm oil farm price in lagged one and two (PCFP_{t-1}, PCFP_{t-2}), fertiliser price (FTP), rainfall lagged one (Rainfall_{t-1}) and temperature (TEMPER). Based on Table 3, the empirical results show that the climate determinant variables (Rainfall and Temperature) have estimated negative sign and statistically significant at 5% significance level at the

rainfall of lagged one year, whereas the temperature is statistically insignificant. The results are supported by Lam Kuok Choy (2014), Zahid Zainal et al. (2012), H. V. Corley and P. B. H. Tinker (2015) and Christopher (2012). In addition, even though the farm price lagged two, fertiliser and trend are estimated positive sign, it is still not statistically significant. The values of climate coefficients (Rainfall and temperature) convey that they have strong impact on palm yield and the effect caused by the temperature is very powerful. In other words, a temperature increase by 1% would cause the palm oil yield to decline by 1.13567% and a rainfall increase by 1% would drop the palm yield by 0.18518%.

Table.1: Augmented Dickey Fuller (Unit Root) Test Results

Variable	Augmented Dickey Fuller				Stationary
	Level		First Difference		
	Constant Without Trend	Constant With Trend	Constant Without Trend	Constant With Trend	
PCFP	-1.742379	-2.833025	-5.785631***	-5.638170***	I(1)
PCYD _{T0}	-0.275038	-3.447721*	-8.309123***	-8.305728***	I(1)
RAINFALL	-4.021853***	-4.135785**	-4.287250***	-4.168478**	I(0)
TEMPERATURE	-0.33788	-6.269207***	-8.263086***	-7.951693***	I(1)
FTP	-2.767618*	-3.730227**	-7.702798***	-3.191559**	I(0)

Table.2: ARDL Bound Test of Long-Run Co-integration

Equation	Lag	F-statistic	Wald test (Fs)
Palm: PCYD _{T0} =f(PCFP, FTP, RAIN, TEMP)	2	4.1773*	3.812749**

Table.3: The ARDL Results of Climate Palm Yield(PCYD_{T0})

C	PCYD _{T0} (-1)	PCFP(-1)	PCFP(-2)	FTP	RAINFALL(-1)	TEMPR	T
6.65375	0.373247	-0.02325	0.008216	0.059191	-0.18518	-1.13567	0.003268
2.379429**	1.771064*	-0.64611	0.24043	1.641721	-2.164413**	-1.3883	1.017653

Diagnostic Tests

Test Statistics	Test Statistics	F [prob.]
R-Squared	0.826137	Serial Correlation 0.2360[.635]
R-Bar-Squared	0.745000	Functional Form 0.6298[.4428]
F Test	10.18208 [0.00010]	Normality 0.7189[.6980]
DW-statistic	2.044386	Heteroscedasticity 0.6577[.7190]

Table.4: The Summary Results of the Validation Tests

Endogenous	RMSE	MAE	U ^T	U ^B	U ^V	U ^C
Palm LPCYD _{T0}	0.022479	0.018329	0.004023	0.000036	0.026471	0.973493

Note: ***, **, and * denote significant at 1%, 5%, and 10% significance levels, respectively.

Note: RMSE = Root Mean Squared Error; MAE = Mean Absolute Error; U^T = Theil Inequality Coefficient; U^B = Fraction of error due to bias; U^V = Fraction of error due to variance; U^C = Fraction of error due to covariance.

Table.5: The Summary Results of the Validation Out of the Sample Test

Endogenous	RMSPE (%)	U^T
Palm LPCYDТО	0.747303	0.004905

Note: RMSPE = Root Mean Squared Percentage Error; U^T = Theil Inequality Coefficient

Figure 2 shows the simulation results for palm oil yield under the three scenarios (scenario 1, 2 and 3). All projections are between the periods (2015 – 2020). In scenario 1 (the projected changes (5% increase) in rainfall), palm oil yield will increase from 17.90 t/ha in 2015 to 18.46 t/ha in 2020. However, the overall trend compared to the baseline is negative and expected to drop by -0.24% annually. Likewise in scenario 2 (the projected changes (2% increase) in temperature), the yield will increase from 17.66 t/ha in 2015 to 18.06 t/ha in 2020 while the total trend compared to the baseline is also negative and expected to decline by -0.58% annually. In scenario 3 (the projected simultaneous changes (+5%) and (+2%) in rainfall and temperature respectively), palm oil yield will increase from 17.51 t/ha in 2015 to 17.81 t/ha in 2020. Similar to scenario 1 and 2, the aggregate trend compared to the baseline is negative and expected to drop by -0.82% annually. Finally, the results revealed that the overall trend is positive. However, climate change will still have negative impacts on the industry.

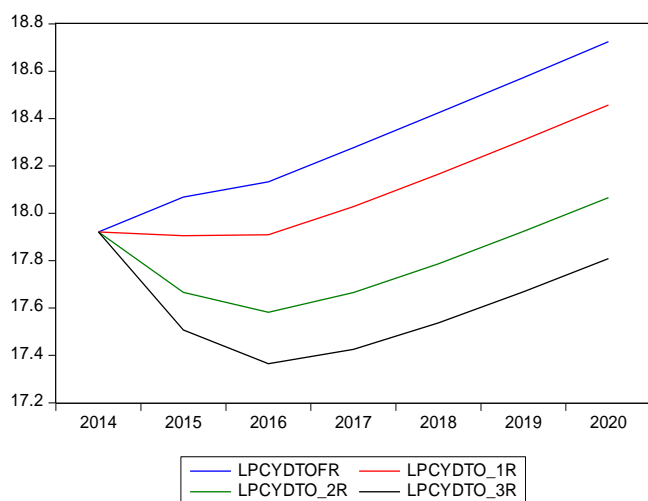

Fig.2: Simulation Results of Palm Yield Scenario1, 2, 3 and Base line

IV. CONCLUSION

Palm oil is the most important agricultural commodity in Malaysia and contributes the highest share to the total agricultural GDP. The result showed that climate variables (rainfall and temperature) have negative impacts on palm oil yield. The production trend is expected to be positive while changes in rainfall (5% increase), changes in temperature (2% increase) and simultaneous changes in

rainfall (+5%) and temperature (+2%) will cause the yield to decline by 0.24%, 0.58%, and 0.82% respectively. Therefore, based on the negative effect of climate change on palm oil yield and the extensive nature of investments in this sub-sector, more detailed studies are required especially on rainfall and its effect on palm oil yield.

REFERENCES

- [1] AGEB, 2015. Arbeitsgemeinschaft Energiebilanz (AGEB).<https://www.rainforest-rescue.org/topics/palm-oil>
- [2] Asari, F.F, Hayati, N.H.A, Razak, E.A.A, Ahmad, B.A.S, Harun, N.F.A, and Jusoff, K., 2011. A Time Series Analysis of the Relationship Between Total Area Planted, Palm Oil Price and Production of Malaysian Palm Oil, World Applied Sciences Journal, Vol. 12, pp. 34 - 40.
- [3] Auffhammer, M., Hsiang, S. M., Schlenker, W., and Sobel, A., 2013. Using weather data and climate model output in economic analyses of climate change. Review of Environmental Economics and Policy, ret016.
- [4] Bank Negara Malaysia, 2011. Bank Negara Malaysia Annual Report 2011, P27
- [5] Basiron, Y., 2007. Pakistan-Malaysia Palm Oil Trade: Why Buy Malaysian Palm Oil, presentation slide Downloadable from: <http://cfile213.uf.daum.net/attach/20172A574DAFE5E4179D63>, retrieved on 08 January 2011.
- [6] Brodie, J. F. (2016). Synergistic effects of climate change and agricultural land use on mammals. Frontiers in Ecology and the Environment, 14(1), 20-26.
- [7] Christopher Teh Boon Sung, 2012. Effect of climate change on oil palm yield in Malaysia: Some simulations, Extraordinary Minds Discuss Ideas.
- [8] Corley, R. H. V., Tinker, P. B. H., 2015. The Oil Palm, 5th Edition, ISBN: 978-1-4051-8939-2, 680 pages. October 2015, Wiley-Blackwell
- [9] Dell, M., Jones, B. F., and Olken, B. A., 2014. What do we learn from the weather? The new climate–economy literature. Journal of Economic Literature, 52(3), 740-798.
- [10] Edy Sigit Sutarta, Heri Santoso, and M. A. Yusuf, 2015. Climate Change on Oil Palm: It's Impacts and Adaptation Strategies. <https://www.researchgate.net/publication>.

[11] Faruk, A., Belabut, D., Ahmad, N., Knell, R. J. and Garner, T. W. J. (2013), Effects of Oil-Palm Plantations on Diversity of Tropical Anurans. *Conservation Biology*, 27: 615–624.

[12] Jamal Othman, and Yaghoob Jafari, 2014. Selected Research Issues in the Malaysian Agricultural Sector. *Jurnal Ekonomi Malaysia*, 482, 127–136. \cite{JamalOthman2014}

[13] Kwan Kok Foo, 2010. Climate Prediction and Information for Decision Making in Malaysia, APEC Climate Symposium 2010, APEC Climate Centre APCC, Busan, Korea, 20 –24 June 2010.

[14] Lam Kuok Choy, 2014. The analysis of rainfall variability and response of oil palm phenology in tropical climate using MODIS vegetation index, Rotterdam, The Netherlands.

[15] Malaysian Investment Development Authority (MIDA), 2012

[16] Malaysian Palm Oil Board (MPOB), 2015. Malaysian Oil Palm Statistics, various issues (2014-2015).

[17] MP, 2015. Eleventh Malaysian Plan, 2016-2020, Kuala Lumpur: Government Printers

[18] Nelson Fu Yee Kium, Master of Science, 2014. Analysis of Malaysian Pepper Market Model.

[19] Paterson, R. R. M. et al. Future climate effects on suitability for growth of oil palms in Malaysia and Indonesia. *Sci. Rep.* 5, 14457; doi: 10.1038/srep14457 (2015).

[20] Pesaran, M. H., and B. Pesaran, 1997. Working with Micofit 4.0: Interactive Econometrics Analysis. Oxford University Press, Oxford.

[21] Pesaran, M. H., Shin Y. and Smith R. J., 2001. Bounds Testing Approaches to the Analysis of Level Relationships. *Journal of Applied Econometrics* 16,289-326.

[22] Pindyck, R. S., 2013. Climate change policy: What do the models tell us? *Journal of Economic Literature*, 513, 860-872.

[23] Shamsudin, M. N. (2008) Econometric Modelling For Agricultural Policy Analysis and Forecasting: Between Theory and Reality, *Journal of Quantitative Methods*, Vol. 4(2), pp. 1 — 18.

[24] Talib, B.A., and Darawi Z., 2002. An Economic Analysis of the Malaysian Palm Oil Market, *Oil Palm Industry Economic Journal*, 2(1), 19-27.

[25] Vaghefi, N., Shamsudin, M. N., Makmom A., and Bagheri, M. (2011). The economic impacts of climate change on the rice production in Malaysia. *Int. J. Agric. Res.*, 6: 67-74.

[26] WWF, 2016. <http://www.worldwildlife.org/initiatives/climate>

[27] Zahid, Z., M. Nasir, S., Zainalabidin, M., and Shehu Usman, A, 2012. Economic Impact of Climate Change on the Malaysian Palm Oil Production. *Trends in Applied Sciences Research*, 710, 872–880.

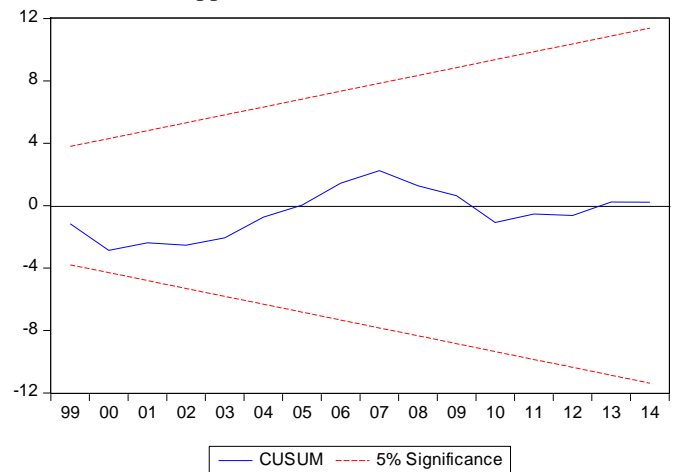

Fig.3: Cusum Test of Palm Yield Model

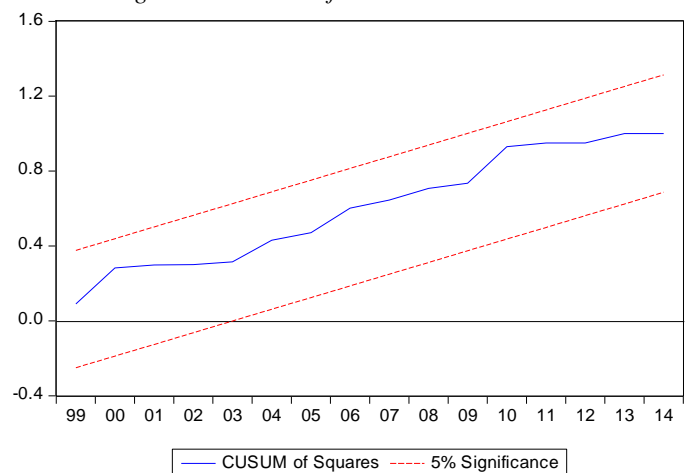

Fig.4: Cusum of Square Test of Palm Yield Model